



innermost®

innermost®

With our core belief that 'light is a material', we thrive from taking wild ideas and creating beautiful, thoughtful and innovative products.

Founded by Steve Jones and Russell Cameron in London in 1999, we continue to work with exciting designers from all over the world to craft a contemporary lighting collection of the absolute highest quality. With an instinctive desire to rebel from the norm, we utilise materials and processes in unique ways to defy expectation.

Innermost products speak of craftsmanship as we design everything with longevity in mind. We are as 'British as London itself': an incongruous mixture of classic English tradition and vibrant global diversity.



reddot award 2017
winner lighting design





darc awards
/ DECORATIVE
CELEBRATING THE BEST IN LIGHTING DESIGN

dezeen
awards







Content



Bud
12-17



Portobello
18-21



Chelsea
22-25



Hoxton
26-29



Hoxton Wall
30-31



Latitude
32-37



Jeeves
38-41



Jeeves Wall
42-43



Jeeves Table
44-45



Cobra
46-47



Core
48-51



Jelly
52-55



Boule
56-59



Pomelo
60-61



Drop
62-65



Yoy Wall
66-67



Foundry
68-71



Purl
72-75



Bolt
76-77



Bracket
78-79



DropLED Fitting
80-83



CAE
84-85



Custom colours

We now offer a custom colour service meaning all products marked with this icon can be customised to any standard RAL colour* of your choice, with minimums as low as one. This service offers an affordable way to achieve a custom finish for a single interior or a large-scale project.







darc awards
/ RECREATIVE
CELEBRATING THE BEST IN LIGHTING DESIGN

dezeen
awards

Bud

By Melissa Yip



Bud is a go-anywhere do-anything LED lamp. Whether illuminating a night picnic, a romantic rooftop dinner or an indoor play den, this rechargeable portable lamp frees you from the constraints of cables, with a three step dimming function to adjust to any situation.

Imitating nature, the globe bulb is shelled by two petal-like forms which appear to simultaneously hold and protect the light. Interact with Bud's bulb to activate the light and dimming function. The tapered cylindrical form encases the translucent globe on top of a thin silicone pad that allows it be pushed to adjust dimming. Push down on Bud's bulb to activate the light and press again to increase the light intensity from 25% to 50% to 100%.

Bud is available in 6 pleasingly solid colours.







Fluro
UK/EU: LB13210511

Ocean
UK/EU: LB13210512

Olive
UK/EU: LB13210513

Aubergine
UK/EU: LB13210526

Lemon
UK/EU: LB13210527

Ash
UK/EU: LB13210544

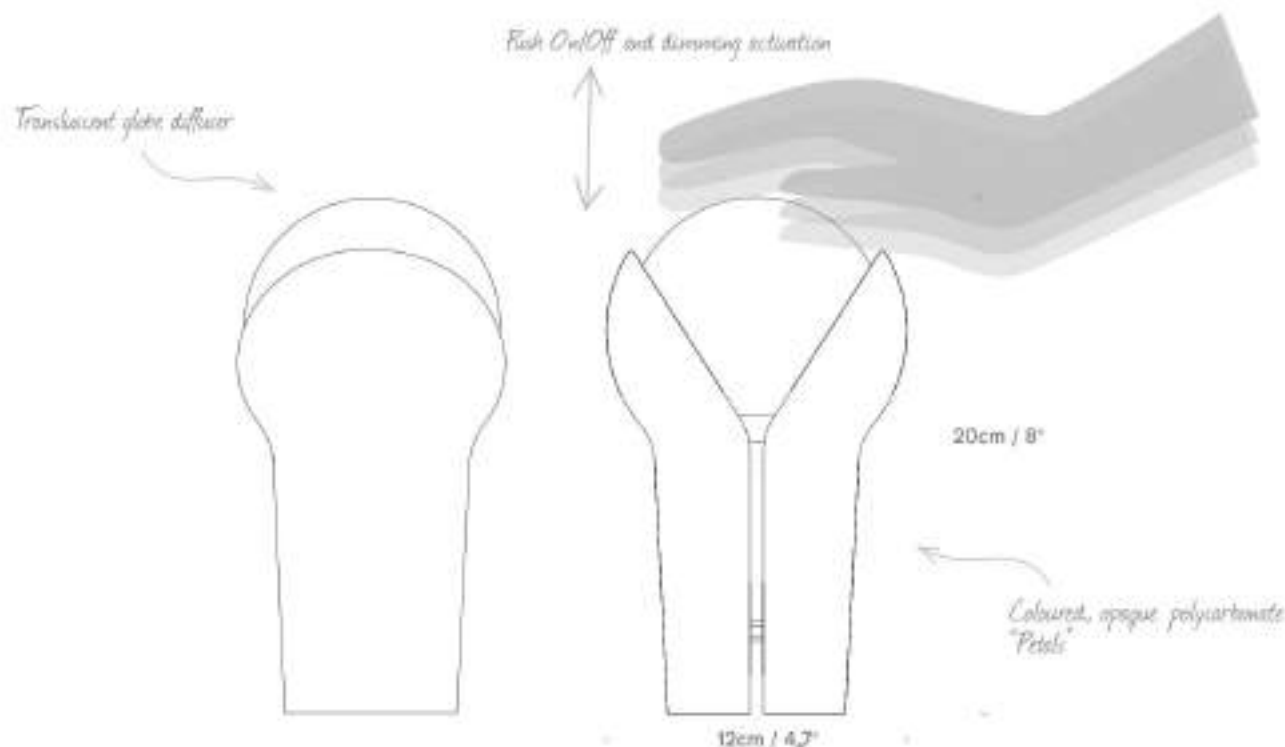

bud

by Melissa Yip

Material	Polycarbonate
Colour	Fluro/ Ocean/ Olive/ Aubergine/ Lemon/ Ash
Lightsource	1W LED rechargeable portable table light LED 2700K, CRI 80, Class III, 90 Lumen 20 hours maximum battery life (5hr battery life at 100%, 10hr at 50%, and 20hr at 25%) 5 hours to fully recharge
Other	NI-MH battery 3.6V / 2000mAh 3-step dimmer switch (dimming percentage: 25%, 50%, 100%) Micro USB Cable
Splash-proof	Bud is splashproof and rainproof so you can use it outside. If your Bud gets wet please ensure it is completely dry before charging - we recommend you leave Bud upside down for a day to dry before using it again. Bud should not be submerged in water or taken into the shower and should not be left outside overnight as it is not designed for that.



Portobello

By Assemblyroom



Simultaneously familiar and new, Portobello is an aesthetic that fits anywhere. Strong gloss colours and the ability to easily customise add value to a form that is simplicity itself.

Constructed from hand spun aluminium, it draws inspiration from the simplicity and functionality of industrial pendant lights of a bygone era. With its scale, defined outline and its two tone colour scheme (coloured exterior, white interior) this large contemporary classic pendant light will have an impact on any room.

Portobello can also be ordered in a custom colour, available for a quantity of 1 unit or more.



White UK/EU: PP09913001 US: PP09933001	Black UK/EU: PP09913002 US: PP09933002	Red UK/EU: PP09913008 US: PP09933008	Yellow UK/EU: PP09913027 US: PP09933027
-----------------------------------------------------	-----------------------------------------------------	---------------------------------------------------	------------------------------------------------------

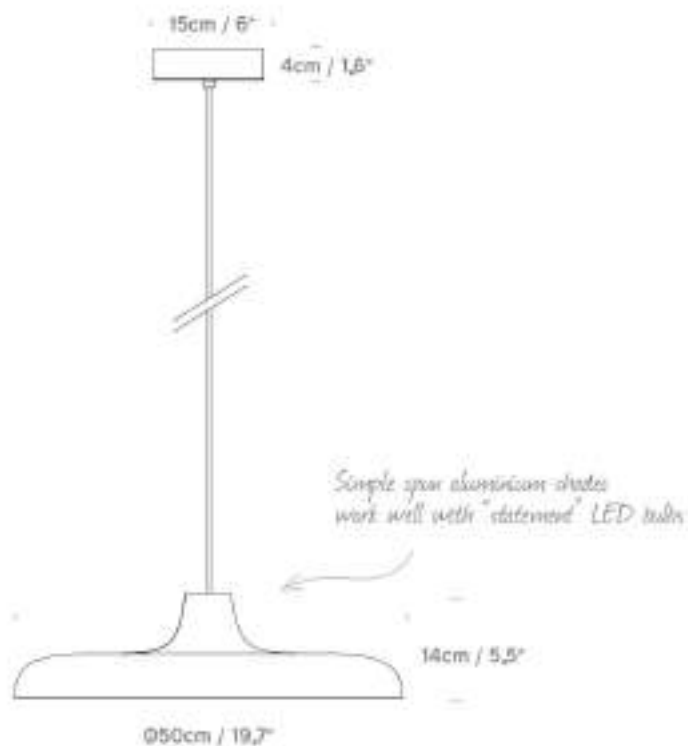

Material	Aluminium
Colour	White/ Black/ Red/ Yellow
Lightsource	UK/EU E27 Max 15W LED, USA E26 Max 15W LED (not included)
Recommended bulb	LED globe bulbs 400 -1000 lumen output and from 2700K (for warmer with more colour) up to 6000K (daylight)
Ceiling Rose	White Cylindrical
Cable	1.2m White PVC cable



Chelsea

By James Bartlett



The new range of spun aluminium pendant lights designed by James Bartlett. With a simple form that is reminiscent of an upturned teacup, these classic pendants are named after a traditional variety of teaware whose shape was identified as 'Chelsea'.

Each model is available in a choice of white interior, or in classic matt Black or White exterior with contrasting antique gold interior. Light also spills from the top to create a delicate illumination around the exterior.

These simple forms create beautiful pendants that suit a wide variety of applications. The versatile range works perfectly as a cluster, particularly effective with multiple colour choices.

Portobello can also be ordered in a custom colour, available for a quantity of 1 unit or more.



Chelsea 40 at Private Residence



Chelsea 10 in custom colour at Private Residence

Chelsea 18

White
UK/EU: PC10911801
US: PC10931801

Black
UK/EU: PC10911802
US: PC10931802

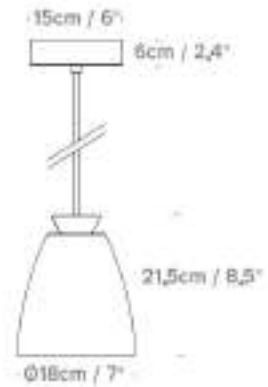

Chelsea 40

White
UK/EU: PC10914001
US: PC10934001

Black
UK/EU: PC10914002
US: PC10934002

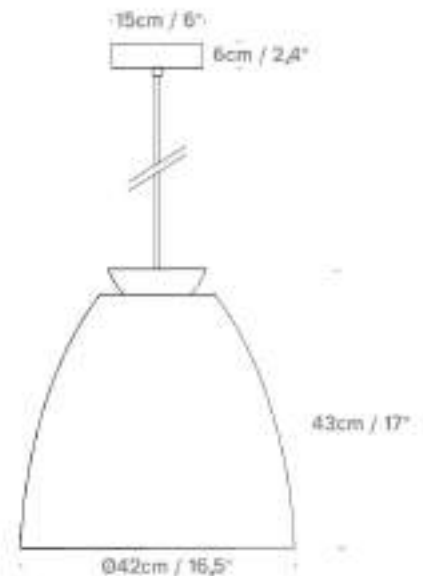

Chelsea 56

White
UK/EU: PC10915601
US: PC10935601

Black
UK/EU: PC10915602
US: PC10935602

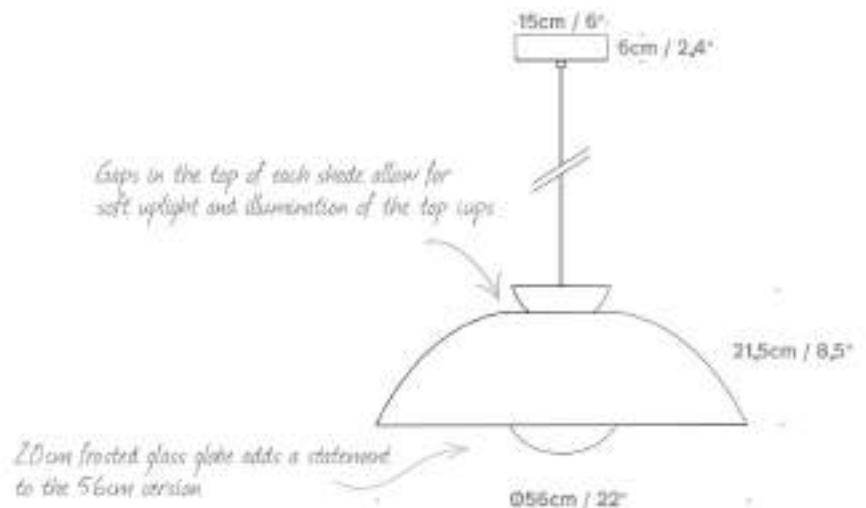

Material

Aluminium, Steel

Colour

White with antique gold interior / Black with antique gold interior

Lightsource

UK/EU E27 Max 15W LED, USA E26 Max 15W LED (not included)

Recommended Bulb

LED globe bulbs 400 -1000 lumen output and from 2700K (for warmer with more colour) up to 6000K (daylight)

Ceiling Rose

Cylinder. Colour to match product.

Cable

Black - 4m Black Braided

All other colour - 4m White Braided





Hoxton

By Bartlett and Jones



Hoxton is a curvilinear pendant light with three angled facets in spun aluminium, that creates a simple yet striking aesthetic. At the heart of the East End of London, Hoxton is an area of innovation and re-invention. Despite changing trends the area retains a solid sense of identity and functionality, which inspired this collection, also reminiscent of industrial building machinery.

Designed by Steve Jones and James Bartlett, this is the first joint project the pair have completed together from start to finish.

The pendants come in two diameter options: Hoxton 17 perfect for bar counter tops and clusters, and Hoxton 50 which suits large spaces.

Portobello can also be ordered in a custom colour, available for a quantity of 1 unit or more.



Hoxton 50 at Private Residence

Hoxton 17

White
UK/EU: PH04911701
US: PH04911701

Black
UK/EU: PH04911702
US: PH04911702

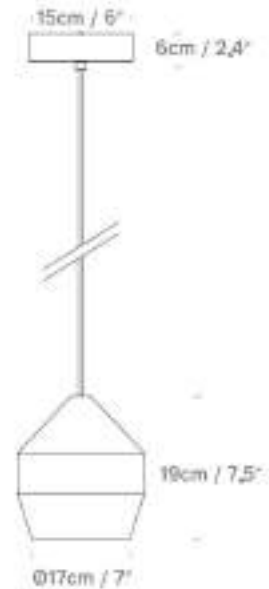

Hoxton 50

White
UK/EU: PH04915001
US: PH04915001

Black
UK/EU: PH04915002
US: PH04915002

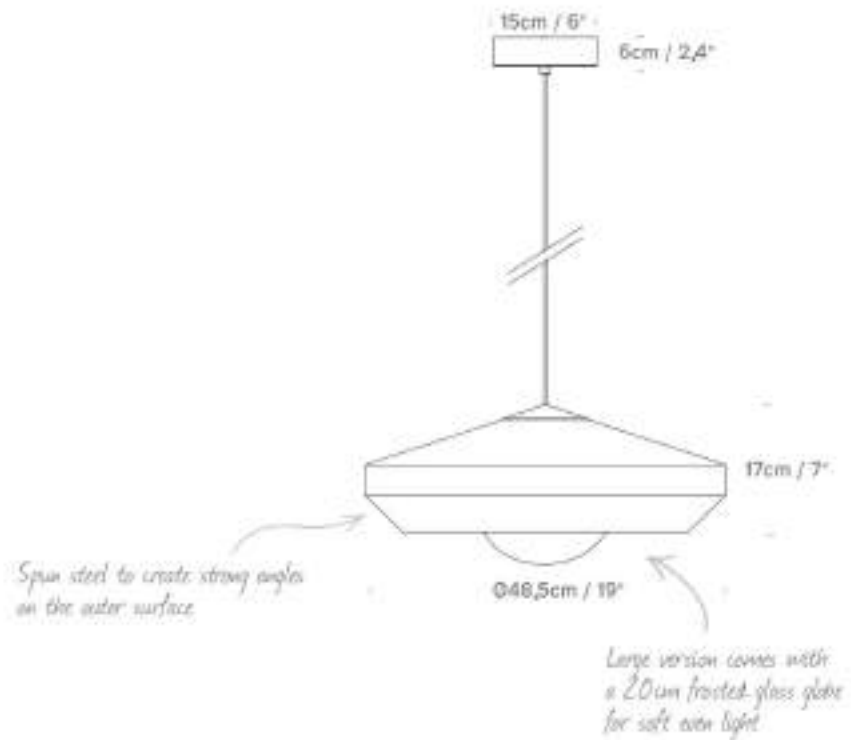

Material

Steel

Colour

White with antique gold interior / Black with antique gold interior

Lightsource

UK/EU E27 Max 15W LED, USA E26 Max 15W LED (not included)

Recommended Bulb

LED globe bulbs 400 -1000 lumen output and from 2700K (for warmer with more colour) up to 6000K (daylight)

Ceiling Rose

Cylinder. Colour to match product.

Cable

Black - 4m Black Braided

All other colour - 4m White Braided





A wall lamp version of the curvilinear Hoxton with three angled facets in spun aluminium. A simple yet striking wall lamp with a delicate stem in matching white, black or grey exterior. The white and black come with antique gold interior for a warm glow. The grey comes with smooth white interior.

Hoxton Wall

By Bartlett and Jones

White
UK/EU: WH078101
US: WH078301

Black
UK/EU: WH078102
US: WH078302

Ball joint allows for gentle rotation of shade for directional lighting & effect.

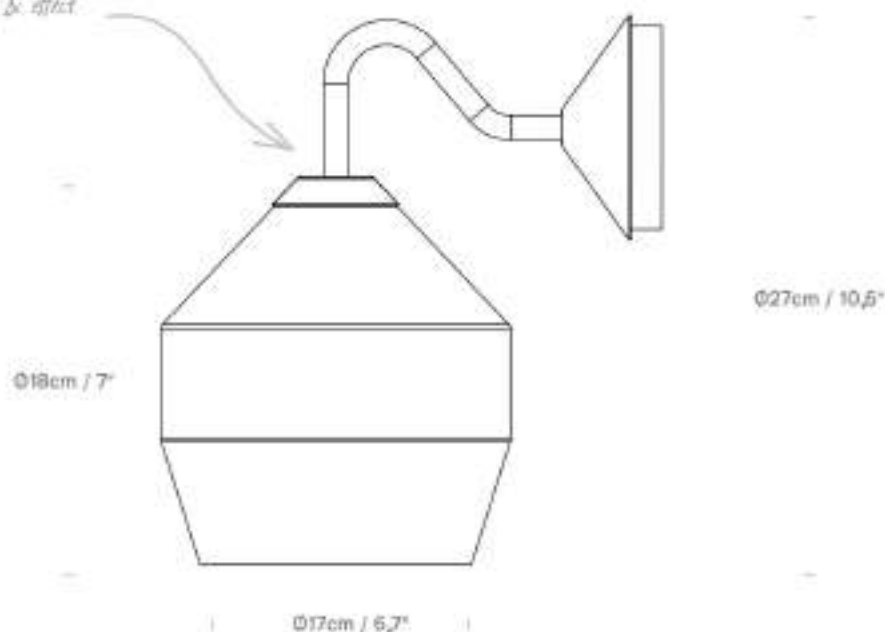

Material

Colour

Lightsource

Recommended Bulb

Projection From Wall

Steel

White with antique gold interior / Black with antique gold interior

UK/EU E27 Max 15W LED, USA E26 Max 15W LED (not included)

LED globe bulbs 400 -1000 lumen output and from 2700K

(for warmer with more colour) up to 6000K (daylight)

24.4cm / 9.6"



Latitude at Morgan Furniture Showroom, London, UK

Latitude

By Flynn Talbot



This is a decorative directional and dimmable LED pendant spotlight with attitude. Flynn transforms the average spotlight to make it the centrepiece rather than mere support lighting.

A clever suspension cable allows the light to be pointed in any direction, creating a flexible light that activates the surrounding space.

When used in multiple colours, hanging at various lengths, and facing different directions, Latitude makes an especially exciting and playful display.



Latitude at Innermost House, USA



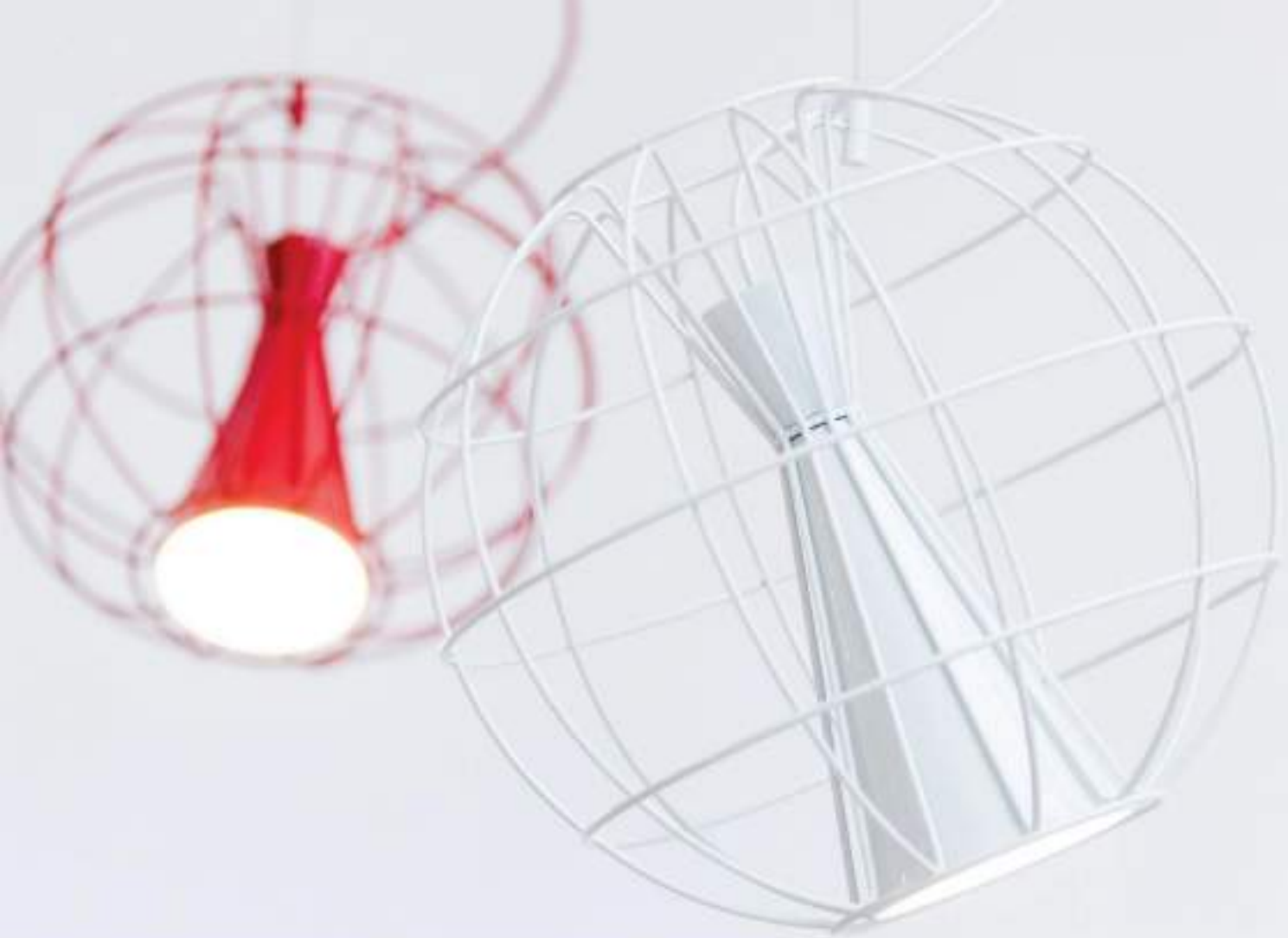

White
UK/EU: PL08913001
US: PL08933001

Black
UK/EU: PL08913002
US: PL089133002

Red
UK/EU: PL08913008
US: PL08913008

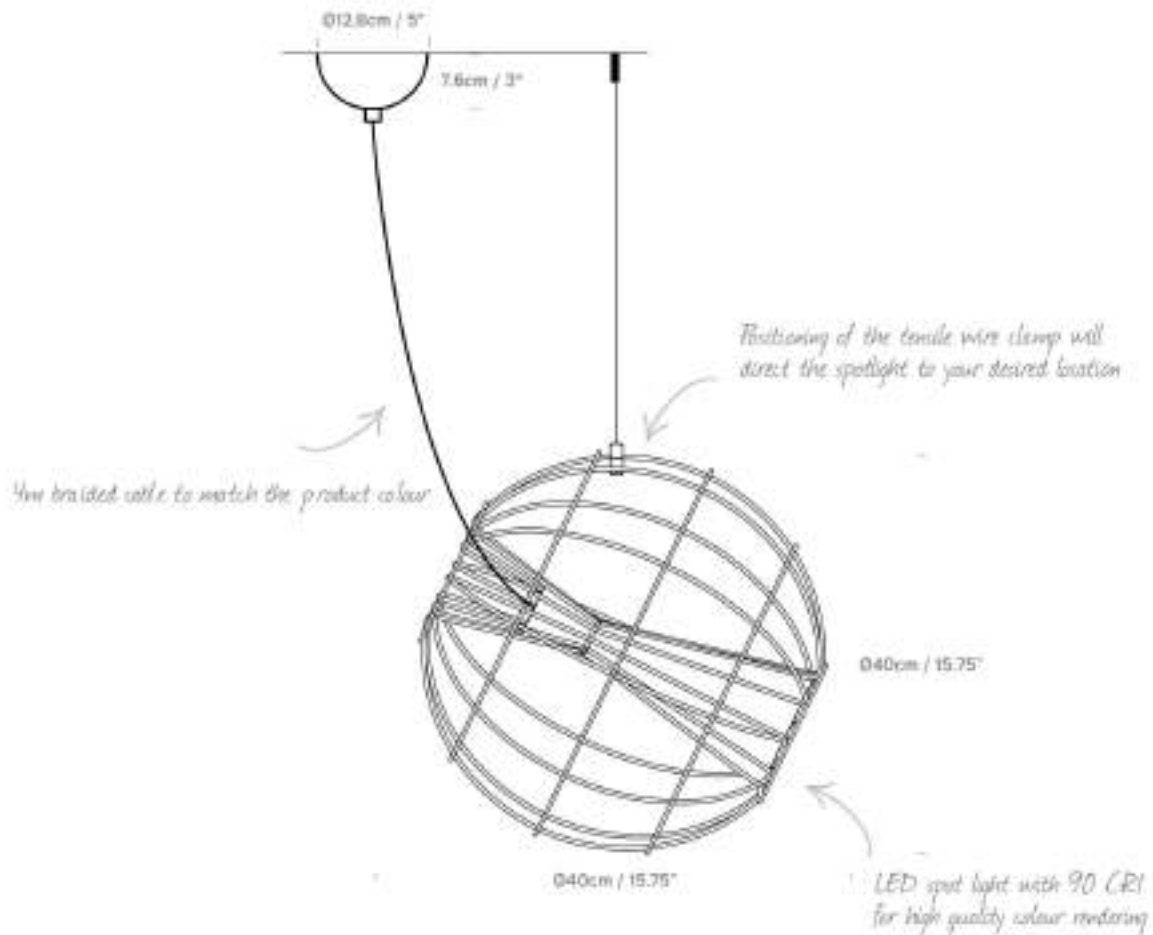

Material	Aluminium and steel
Colour	White / Black / Red
Lightsource	UK/EU 220v USA 120v, integrated 12W LED, 900 lumen, 3000K , CRI 90,
Recommended Bulb	Lutron or triac dimmable cree chip, chip life 30,000 hours, beam angle 60°
Ceiling Rose	Hemisphere. Colour matches product colour
Cable	4m. Braided cable colour matches product colour



Jeeves and Wooster at B&N L's Suite Bruges, Belgium

Jeeves

By Jake Phipps



Jeeves is a blend of tradition and technology, a hand made wool felt hat lined with an aluminium inner shell. Named after PG Wodehouse's iconic and well informed butler character.



Jeeves at Pret-A-Manger Project, London



Jeeves at Restaurant "Sugar Bay" Moscow, Russia



Jeeves at AppDynamics by Fennie + Mehl, San Francisco, USA

Jeeves

Black & Gold
 UK/EU: PJ029102
 US: PJ029302

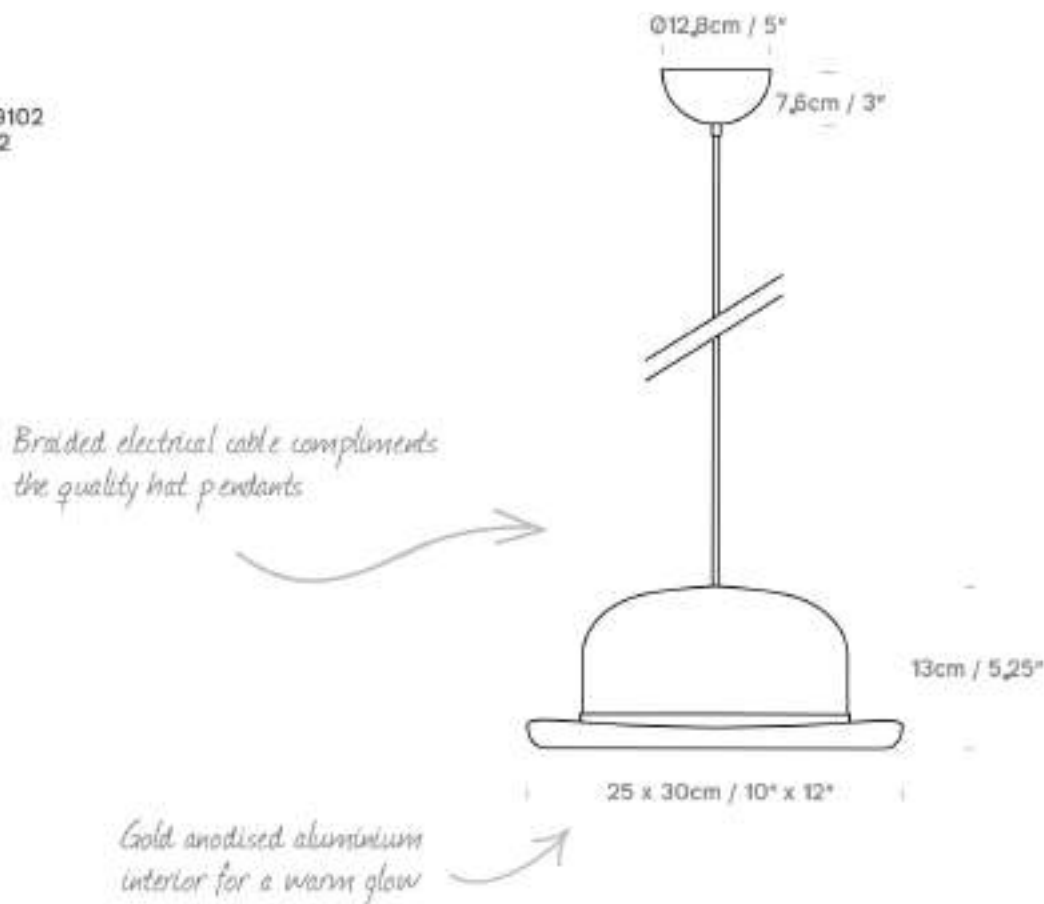

Material	Wool felt bowler hat with anodised aluminium lining
Colour	Jeeves- black with gold anodized interior
Lightsource	UK/EU G9 Max 5W LED, USA G9 Max 5W LED (not included)
Recommended Bulb	LED G9 dimmable bulb up to 500 lumen output and colour temperature from 2200K to 2700K
Ceiling Rose	Black hemisphere
Cable	4m. Black braided cable



A classic gentleman's bowler that looks like it has been thrown very hard at a wall! The anodised gold interior gives a soft warm down light. With an additional feature that allows it to be set at any angle on the wall there is plenty of scope for unique installation ideas.



Jeeves Wall at LinkedIn Office, by IA Interior Architects, Empire State Building, New York, USA

Jeeves Wall

By Jake Phipps

UK/EU: WJ028102
US: WJ028302

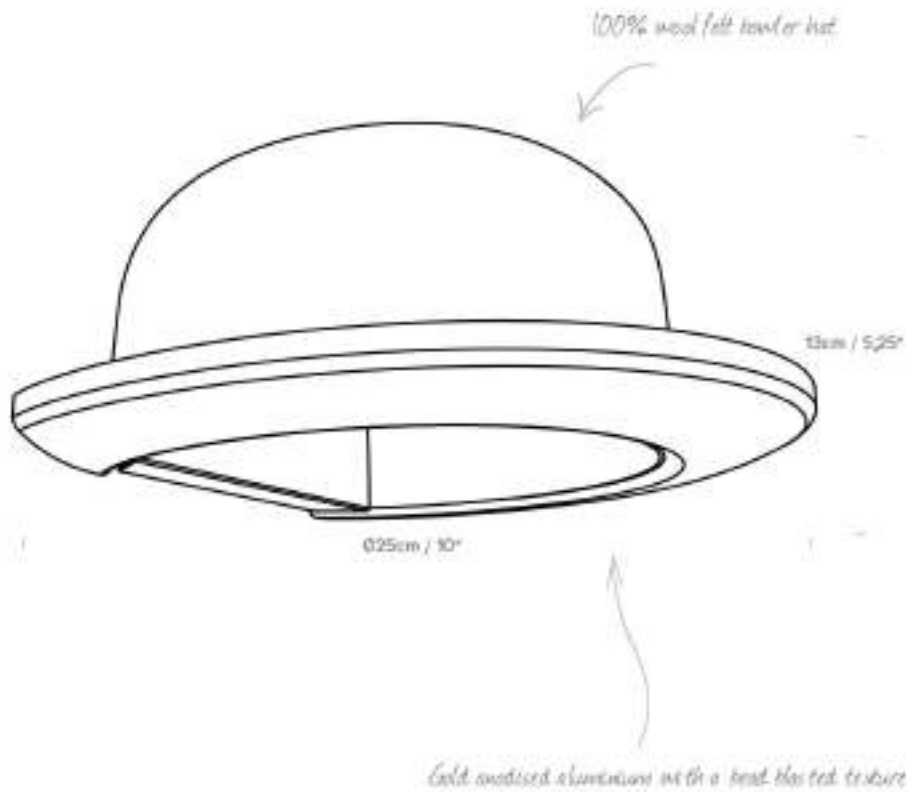

Material	Wool felt with aluminium interior
Colour	Black with gold anodised interior
Lightsource	UK/EU G9 Max 5W LED, USA G9 Max 5W LED (not included)
Recommended Bulb	LED G9 dimmable bulb up to 500 lumen output and colour temperature from 2200K to 2700K
Projection From Wall	23cm / 9"



The quintessentially British bowler hat repurposed as a table lamp. A minimal textured matt black base supports a classic pure wool bowler hat. The top hat can be angled, providing various options for installation; you can even 'tip' your hat to passers by.

Jeeves Table

By Jake Phipps

UK/EU: LJ022102
US: LJ022302



Material	Wool felt with aluminium interior
Colour	Black with gold anodised interior
Lightsource	UK/EU G9 Max 5W LED, USA G9 Max 5W LED (not included)
Recommended Bulb	LED G9 dimmable bulb up to 500 lumen output and colour temperature from 2200K to 2700K
Cable	50cm to inline rocker switch, 1.5m to plug, Black braided cable



Cobra 45 at Private Residence, Toronto, Canada



Cobra 90 at Private Residence, Hong Kong

Cobra is a wall mounted LED bedside light with a fully adjustable flexible stem. Now available with 2 size options, this flexible and smart lamp suits any interior, giving focused, directional illumination. Cobra with 90cm stem comes in white, or brown leather with gold anodized inner hood, or the shorter 45cm Cobra has a painted black or white finish stem.

With touch-activated switch and a USB charging socket, this stylish wall lamp is perfect for modern life.



Cobra

By Innermost

Cobra 90

Material
Steel, aluminium and leather

White
UK/EU: WC07819001
US: WC07839001

White leather upholstery, white inner hood, white semi-gloss switch box

Brown
UK/EU: WC07819010
US: WC07839010

Brown leather upholstery, gold anodised aluminium inner hood, black semi-gloss switch box

Winner of Certificate of Excellence for Best Lighting in Professional Product Design category A&D Trophy Awards 2014

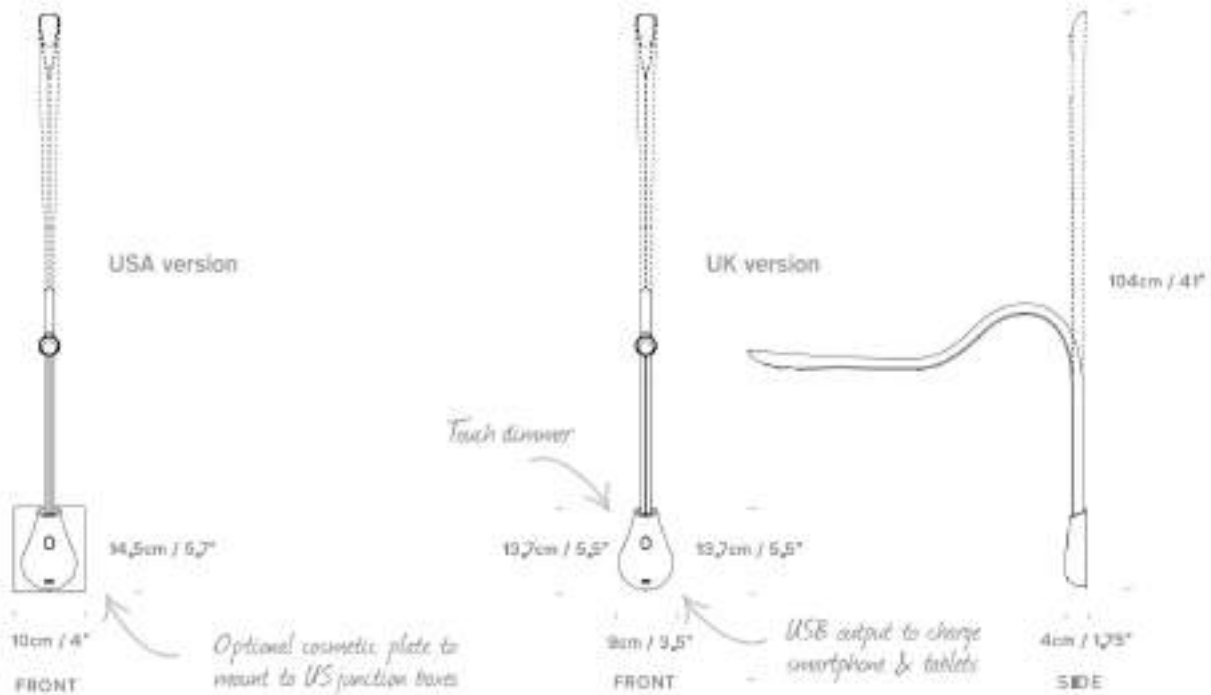

Cobra 45 Nude

Material
Steel and aluminium

White
UK/EU: WC07813501
US: WC07833501

White painted stem, white inner hood, white semi-gloss switch box

Black
UK/EU: WC07813502
US: WC07833502

Black painted stem, gold anodised aluminium inner hood, black semi-gloss switch box

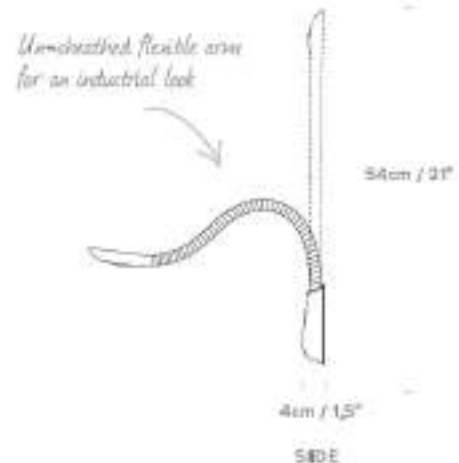

Lightsources

Integrated LED Source, CREE LED, chip life 40,000 hours, 2.5W, 200lm, 3000-3500K, CRI (Ra) 80, Beam Angle 160°

Other

Universal Driver, USB Charger 5V 1.2 mA, touch dimmer switch. Cosmetic plate optional for UK/EU



Coffee at Brasserie fou d'o, by Beluce, Belgium

Core

By Innermost



Core is a glass pendant light manufactured by artisans in the Czech Republic available in two size options. It resembles a parison of molten glass, fresh from the furnace. There is an alluring simplicity to the form, which seems to be slowly shaped by gravity's pull.

Core is available in smoked, clear and white glass finishes.



Core 15

Clear
UK/EU: PC08910500
US: PC08930500

White
UK/EU: PC08910501
US: PC08930501

Silver
UK/EU: PC08910504
US: PC08930504

Smoke
UK/EU: PC08910505
US: PC08930505

Gold
UK/EU: PC08910515
US: PC08930515

*New plated silver & gold
colourways appear
Solid until the lamp is
illuminated to reveal
the beautiful glass form
hidden inside.*

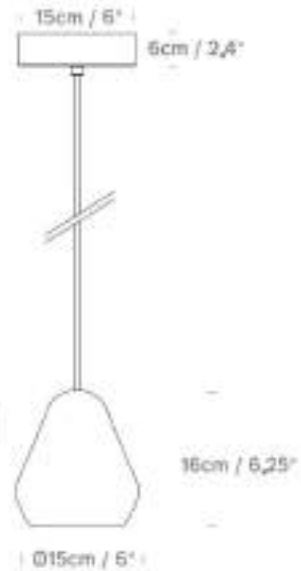

Core 20

Clear
UK/EU: PC08911000
US: PC08931000

White
UK/EU: PC08911001
US: PC08931001

Smoke
UK/EU: PC08911005
US: PC08931005



Material

Colour

Lightsource

Recommended Bulb

Ceiling Rose

Cable

Glass

Clear / White / Smoke

UK/EU E27 Max 15W LED, USA E26 Max 15W LED (not included)

Pearl LED globe dimmable bulbs 300 - 500 lumen output and colour temperature 2700K

Clear and White - white Cylinder

Smoke - black Cylinder

4m PVC cable

Clear and White - white braided cable

Smoke - black braided cable



Jelly

By Stone Designs



Transparent, curvaceous hand blown glass shades that seem to quiver like Jelly in the light, these colourful shades are a visual treat. With four colours the collection truly comes alive when mixed and matched.

This simple minimalist pendant lamp was designed as a pure, colourful form that speaks of the material from which it has been crafted. These pendants will rejuvenate any space they inhabit, providing satisfying bursts of translucent colour.



Jelly at Coca-Cola canteen restaurant, Madrid, Spain



Jelly at Coca-Cola canteen restaurant, Madrid, Spain

Grey
UK/EU: PJ03911005
US: PJ03931005

Red
UK/EU: PJ03911008
US: PJ03931008

Blue
UK/EU: PJ03911012
US: PJ03931012

Yellow
UK/EU: PJ03911027
US: PJ03931027

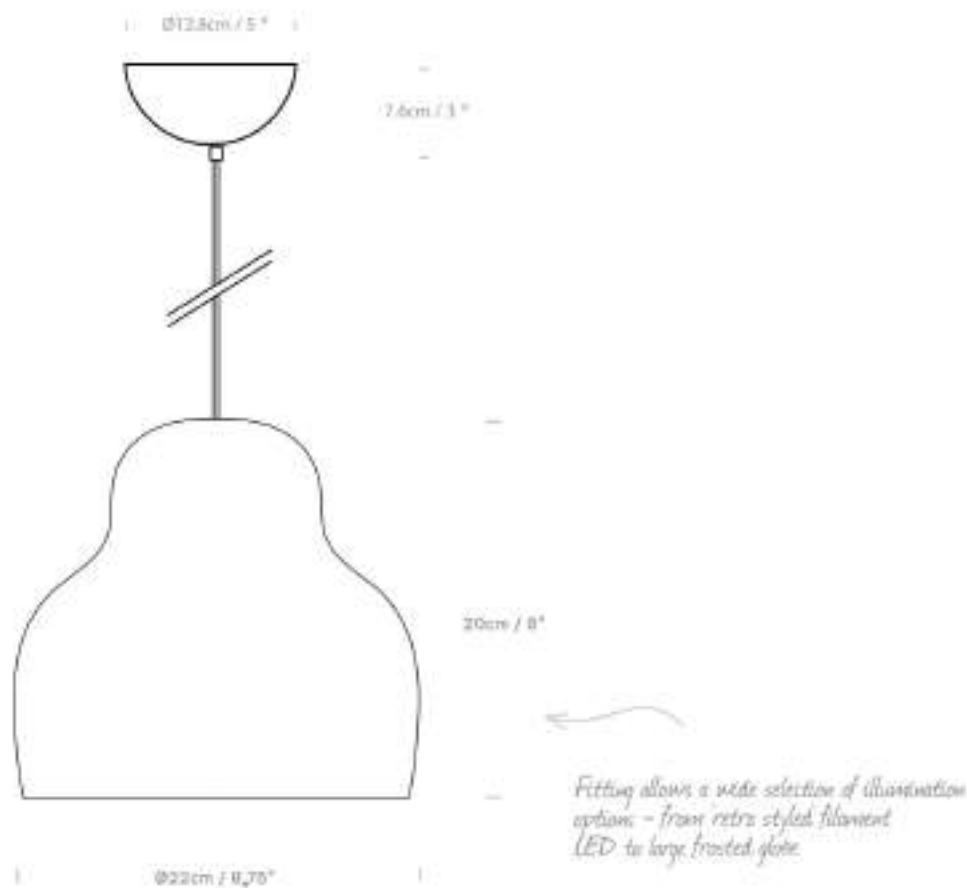

Material

Colour

Lightsource

Recommended Bulb

Ceiling Rose

Cable

Glass

Grey / Red / Blue / Yellow

UK/EU E27 Max 15W LED, USA E26 Max 15W LED (not included)

Filament or pearl LED globe dimmable bulbs 300 - 500 lumen output and colour temperature 2700K

Red / Blue / Yellow - white hemisphere, Grey - black hemisphere

4m. Red, Blue and Yellow - white PVC cable

Grey - black PVC cable



Boule at the Story Lab offices, by Stone Design, Madrid

Boule

By Innermost



Boule is a simple spherical decorative pendant. The metallic finishes and strong solid tones are designed to work in installations with the popular Beads and Bubble pendants. The highly polished spheres create striking reflections of the surrounding interior.

This minimal hanging spot is perfect used on its own, or is particularly dynamic in a cluster to highlight interiors. Boule hangs from a braided cable, in simple colour tones, keeping the focus on the pendant's simplistic form. This small pendant makes a big impact!



Boule at Private Residence Germany
Credit Kreativhaus Wilgmann

White
UK/EU: PB06910501
US: PB06930501

Black
UK/EU: PB06910502
US: PB06930502

Chrome
UK/EU: PB06910503
US: PB06930503

Copper
UK/EU: PB06910507
US: PB06930507

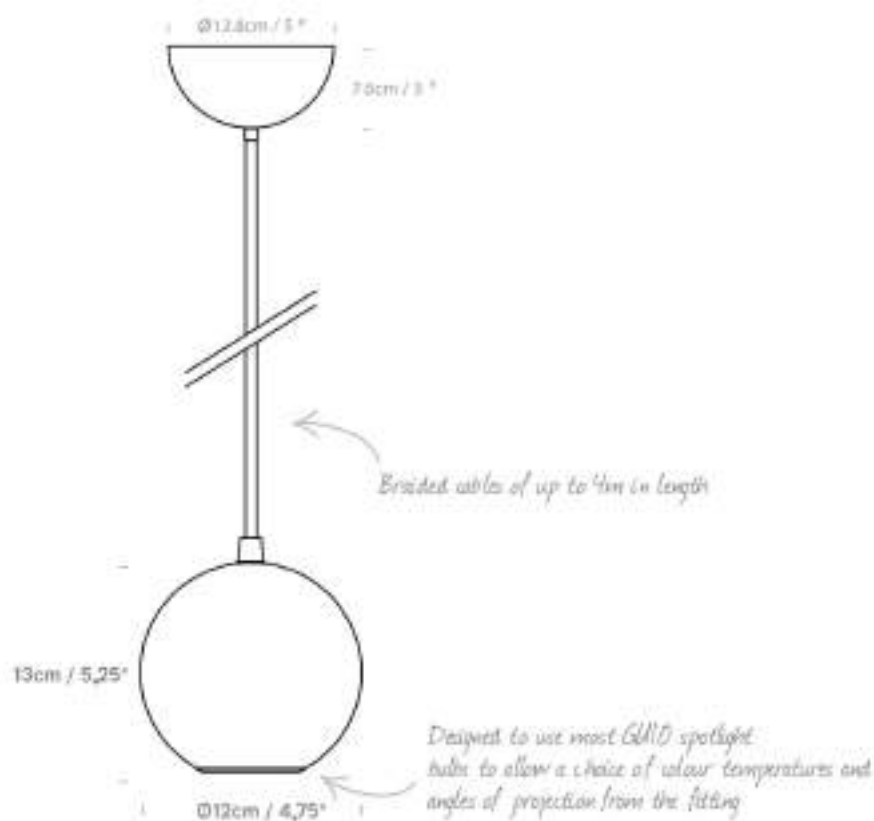

Material

Stainless steel

Colour

White / Black / Chrome / Copper

Lightsource

UK/EU GU10 Max 12W LED, USA GU10 Max 12W LED (not included)

Recommended Bulb

GU10 LED bulb with $\varnothing 5\text{cm} / 2''$ and height $< 6.2\text{cm} / 2.4''$ is suitable for this fitting

Ceiling Rose

Hemisphere, White - white. Black & Copper - black hemisphere

Cable

4m, White - white braided cable

Chrome/Black/Copper - black braided cable



The opal glass pendant light, Pomelo, is deliberately subtle. A quiet diffusion of light in this stately, voluptuous form provides an ambient effect with a sculptural twist.

Made from high quality mouth blown opal glass, Pomelo provides near perfect, shadow-less illumination. The matt look white cable and white scalloped cap compliment the quality glass, which is made by artisans in the Czech Republic.

Pomelo

By Stone Designs

UK/EU: PP06911001
US: PP06931001

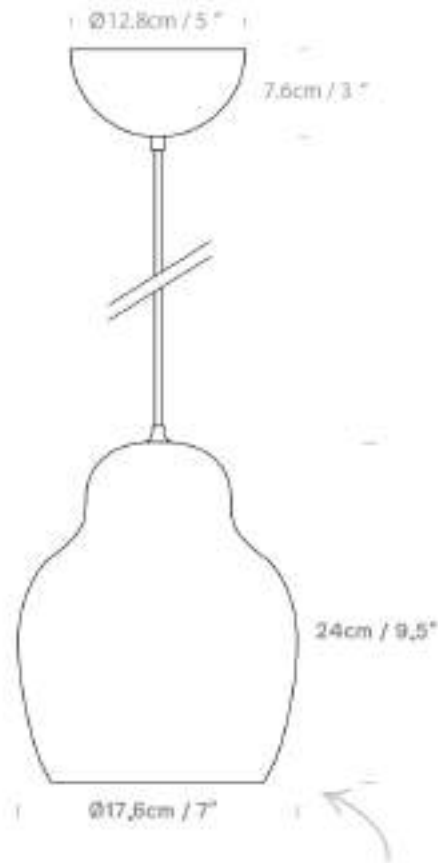

High quality blown glossy opal white glass.

Material

Colour

Lightsource

Recommended Bulb

Ceiling Rose

Cable

Glass

White

UK/EU E27 Max 15W LED, USA E26, Max 15W LED (not included)

LED globe bulbs 400 - 1000 lumen output and from 2700K
(for warmer with more colour) up to 6000K (daylight)

White hemisphere

4m. White PVC cable



Drop

By Innermost



Drop is a frosted glass globe pendant delicately topped with a white powder coated stainless steel cap. Resembling a drop of pristine pearl, it is inspired by the flourishes of the mid-century. These perfect balls of light make a definite statement against any backdrop, particularly when suspended at multiple lengths.

With a perfect circular silhouette, Drop is simplicity that can be used anywhere for the ultimate minimal lighting solution.



Drop 20

White
UK/EU: PD04911001
US: PD04931001

Brass
UK/EU: PD04911030
US: PD04931030

Frosted white glass globe for a soft even glow

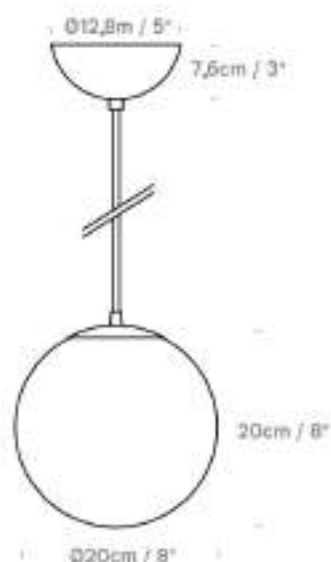

Drop 40

White
UK/EU: PD04912001
US: PD04932001

Brass
UK/EU: PD04912030
US: PD04932030

Brass edition features gold braided cable

Large 40cm glass globe is great complement to the 20cm version, and perfect for filling large spaces

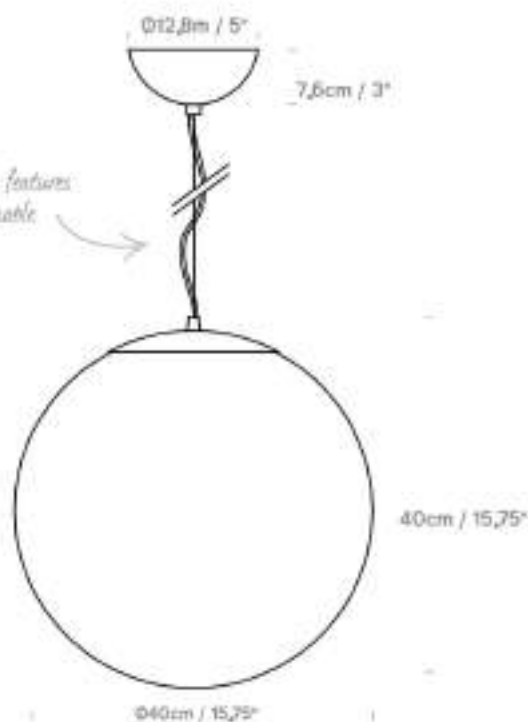

Materials

Colour

Lightsource

Recommended Bulb

Ceiling Rose

Cable

Steel & Glass

White/ Brass

UK/EU E27 Max 15W LED. USA E26 Max 15W LED (not included)

LED globe bulbs 400 - 1000 lumen output and from 2700K (for warmer with more colour) up to 6000K (daylight)

White - White hemisphere

Brass - Brass hemisphere

White - 4m. White braided cable

Brass - 4m. Gold braided cable



Ever defiant of the laws of our reality, YOY presents LED wall & table lights that project an illusion of a classic lamp shade onto the wall. The perfect marriage of illusion and technology; a simple idea very well executed often makes the best product.

YOY hid a tiny but very powerful LED unit inside the head of this minimal lamp and combined it with simple projection principles to make it cleverly project the shape of its own shade.

YOYWall is arguably the most minimal wall sconce possible, interacting with and using the wall in more than just a supporting role. Winner of the 'Red Dot' in Red Dot Award: Product Design 2017.

YOYWall

By YOY

UK/EU: WY018101
US: WY018301

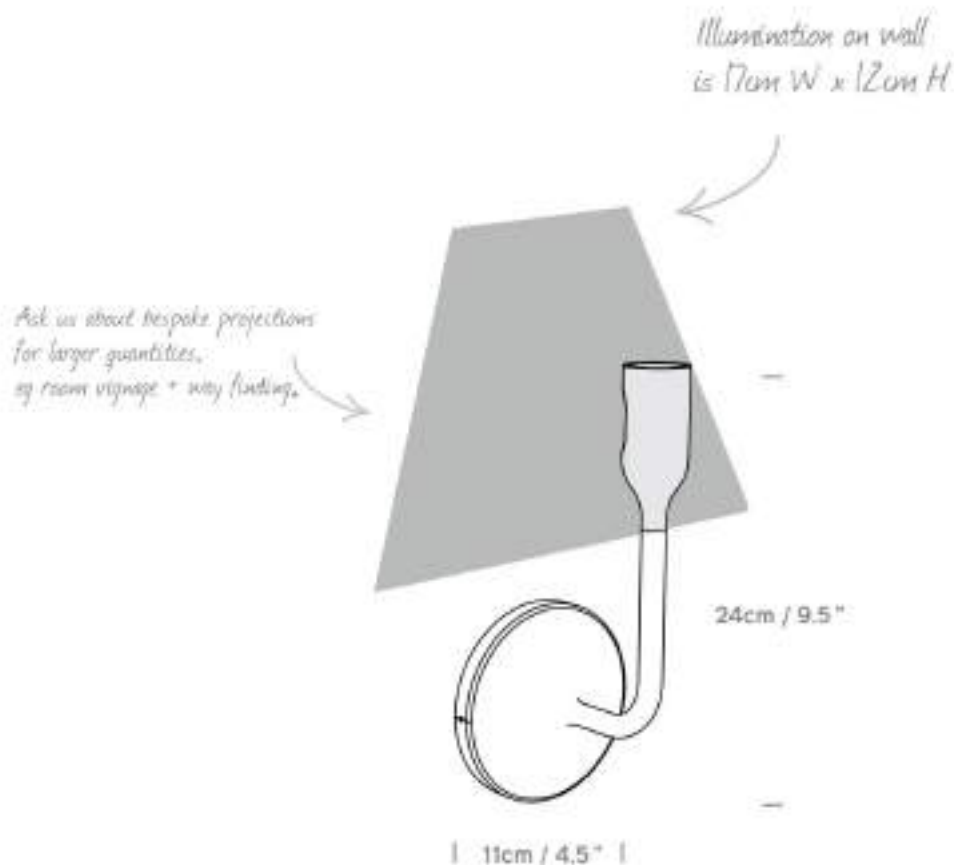

Material	Aluminium and steel
Colour	White
Lightsource	Integrated 3W LED, 100 lumen, 2700K CRI 80. Cree chip, chip life 30,000 hours, beam angle 120° Single product is non-dimmable. Can be dimmable in multiples.
Projection From Wall	10cm / 4"



Foundry

By Innermost



A classic industrial pendant that brings a workshop aesthetic to the Innermost collection. The simplistic spun metal shade is ubiquitous, a staple for any lighting range. Made from spun steel, with the superior quality you can expect from us.



Foundry 40

White
UK/EU: PFO6913001
US: PFO6933001

White LED
UK/EU: PFO7913001
US: PFO7933001

Black
UK/EU: PFO6913002
US: PFO6933002

Black LED
UK/EU: PFO7913002
US: PFO7933002

Red
UK/EU: PFO6913008
US: PFO6933008

Red LED
UK/EU: PFO7913008
US: PFO7933008

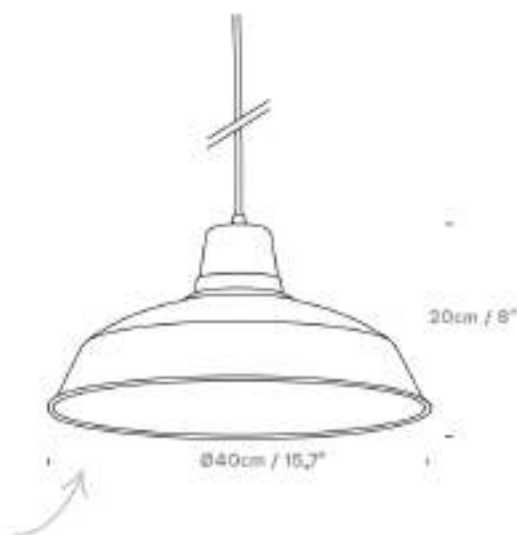

*Foundry can be powered by a simple E27 bulb
or an integrated 12W AC LED.*

Foundry 50

White
UK/EU: PFO6914001
US: PFO6934001

White LED
UK/EU: PFO7914001
US: PFO7934001

Black
UK/EU: PFO6914002
US: PFO6934002

Black LED
UK/EU: PFO7914002
US: PFO7934002

Red
UK/EU: PFO6914008
US: PFO6934008

Red LED
UK/EU: PFO7914008
US: PFO7934008

Foundry is perfect for bespoke colours & finishes

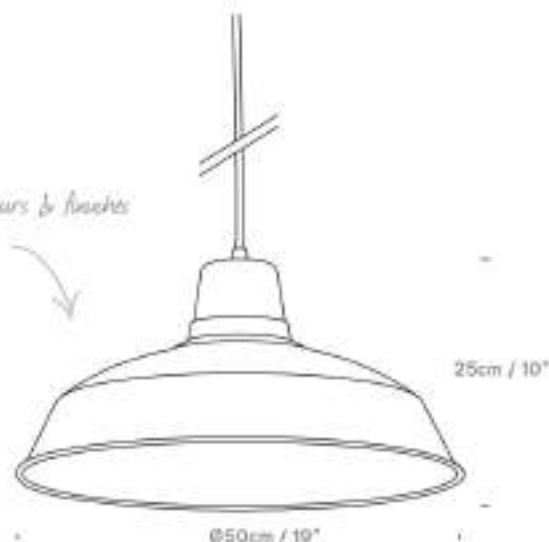

Material

Steel

Colour

White / Black / Red

Lightsource

*other finish options are possible subject to minimums

CAE: UK/EU E27 Max 15W LED, USA E26 Max 15W LED (not included) /
LED: UK/EU 220v USA 120v, CE certified, USA 120v, integrated 12W AC LED Unit,
900 lumen, 3000K, CRI 90, dimmable via Triac / Lutron chip life 30,000hrs,

Ceiling Rose

White Cylindrical, Colour matches ceiling rose and cable is optional

Cable

1.2m White PVC cable

Other

At present Foundry 50 is only available as a bespoke option with x 100 unit MOQ.
Contact us for details.



Purl

By Innermost



Purl takes our popular DropLED line to a new dimension. With the addition of a simple cover and screw on frosted glass ball DropLED becomes Purl - just about the simplest dedicated LED pendant solution on the market today.

With the addition of the decorative Purl cover, this dimmable luminaire consumes minimal energy while providing simple, beautiful lighting. Choose between Brass or Gun Metal fittings with corresponding ceiling rose. Available as a complete unit, or an add-on to an existing DropLED fitting.



Brass
UK/EU: PP10911530
US: PP10931530

Gun Metal
UK/EU: PP10911531
US: PP10931531

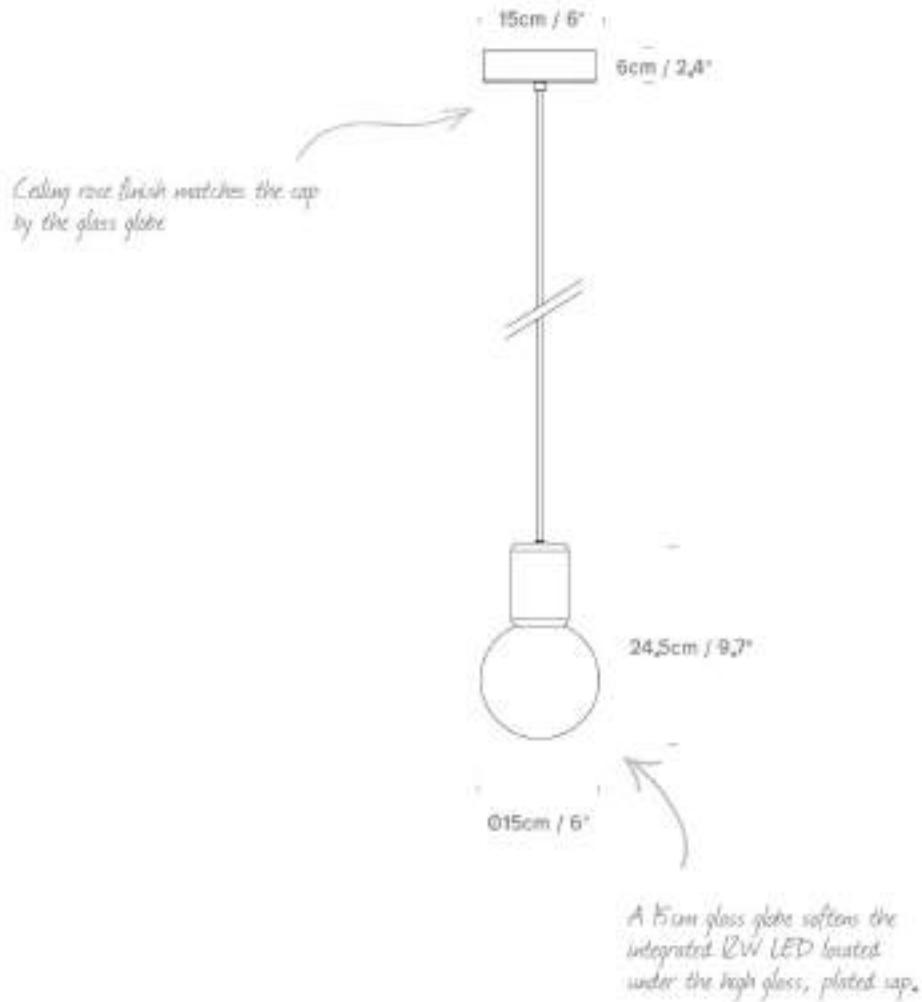

Material	Stainless Steel + Glass
Colour	Brass /Gun Metal
Lightsource	UK/EU 220v CE certified, USA 120v integrated 12W AC LED Unit, 900 lumen, 3000K, CRI 90, dimnable via Triac / Lutron chip life 30,000hrs, compatible with Casambi bluetooth control system
Ceiling Rose	Cylinder. Colour to match fitting
Cable	4m Black PVC



A building's history weighs heavily on each nut and bolt. Reclaim that industrial detail in a contemporary space with this dimmable LED wall sconce, which highlights the honesty of its construction.

Bolt

By Steve Jones

UK/EU: WB078101
US: WB078301

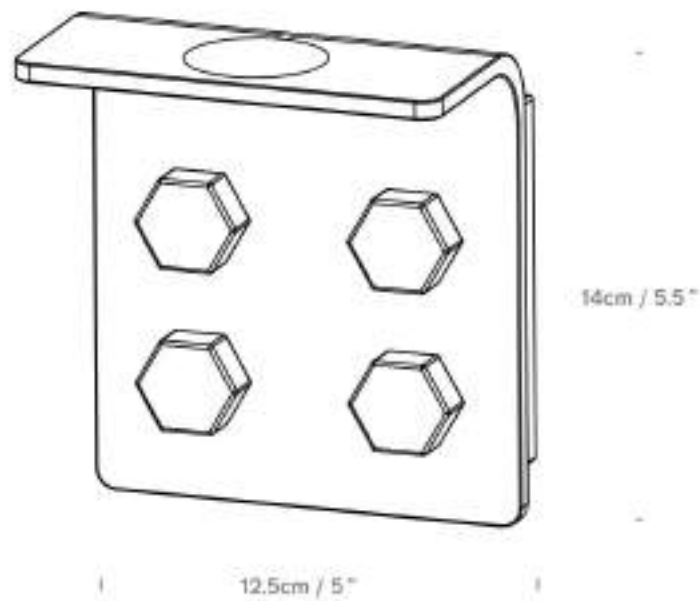

Material	Aluminium
Colour	White
Lightsource	UK/EU 220v USA 120v, integrated LED, 3000K, CRI 93, Sharp chip, chip life 30,000 hours, beam angle 120° UK/EU: 13W, 1150lm, leading / trailing-edge and TRIAC dimmable USA: 12W, 1000lm.
Projection From Wall	10cm / 4"





A simple item that is well considered in proportion, function and technology, this unassuming high performance LED lamp will fit anywhere.

Bracket

By Steve Jones

UK/EU: WB088101
US: WB088301

With its minimal aesthetic and compact design, bracket is perfect for illuminating walls in alcove spaces

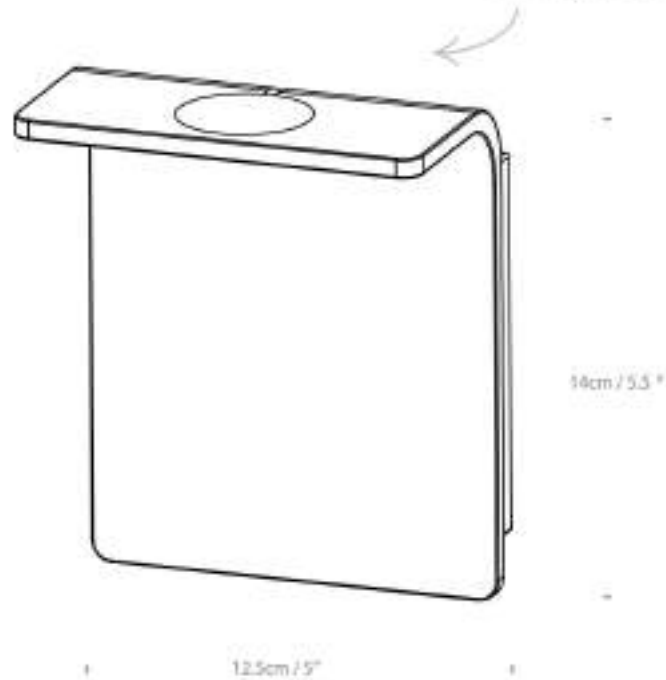

Material	Aluminium
Colour	White
Lightsource	UK/EU 220v USA 120v, integrated LED, 3000K, CRI 93, Sharp chip, chip life 30,000 hours, beam angle 120° UK/EU: 13W, 1150lm, leading / trailing-edge and TRIAC dimmable USA: 12W, 1000lm
Projection From Wall	10cm / 4"





DropLED Fitting

By Innermost



An evolution of the traditional ceiling assembly, DropLED gives all pendants a dedicated LED option. The simple, dimmable LED module does not require complicated installation and consumes minimal energy while providing beautiful lighting.

DropLED fits any standard E27 or E26 shade and comes with 3 lens options that can be easily clipped on to achieve the preferred lighting effect.



White
UK/EU: EC099101
US: EC099301

Black
UK/EU: EC099102
US: EC099302

Satin Nickel
UK/EU: EC099104
US: EC099304

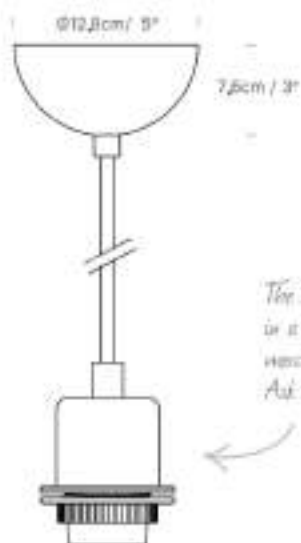

The dimmable AC LED can be used in a standard shade or even added to most of our pendants. Ask us for detail!

Lens attachments

Opal globe diffuser 220°



Clear beam lens 220°



Frosted filament diffuser 210°



With 15cm glass diffuser



The 15cm glass diffuser is an optional extra

15 cm glass globe
EPG1501

Material	Stainless steel
Colour	White/ Black / Satin Nickel
Lightsource	UK/EU 220v CE certified, USA 120v, integrated 12W AC LED Unit, 900 lumen, 3000K, CRI 90, dimmable via Triac / Lutron chip life 30,000 hrs, compatible with Casambi bluetooth control system
Ceiling Rose	Hemisphere. Colour to match fitting
Cable	White- white PVC cable Satin Nickel- clear PVC cable Black- black PVC cable



Innermost CAE Pendant Fittings with integrated wiring set can be used with any E27 or E26 shade ring. With a standard cord length of 1.8m, CAE is available in white and satin nickel, giving a variety of installation options.

CAE

By Innermost

White 1.8m

UK/EU CAE27: EC019101
US CAE26: EC019301

Satin Nickel 1.8m

UK/EU CAE27: EC019104
US CAE26: EC059304

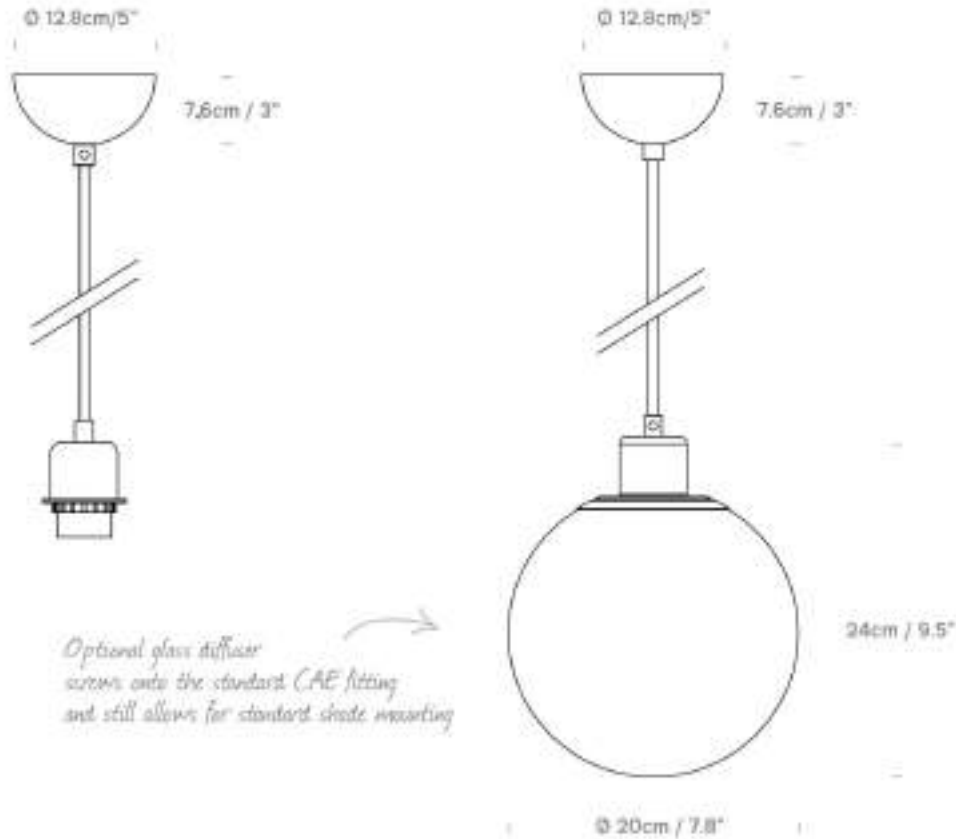

CAE 27

CAE 27
with 20cm frosted glass globe
ECG 2001

Material

Steel

Colour

White / Satin Nickel

Lightsource

UK/EU CAE27 E27 Max 15W LED, USA CAE26 E26 Max 15W LED (not included)

Recommended Bulb

LED globe bulbs 400 - 1000 lumen output and

from 2700K (for warmer with more colour) up to 6000K (daylight)

Ceiling Rose

Hemisphere. Colour to match fitting

Cable

1.8m (longer cable available on request)

White - white PVC cable

Satin Nickel - clear PVC cable



Designers



Assemblyroom

Anthony Dickens founded his London product and furniture design studio in 1998, creating objects that express simple narratives and re-imagine the everyday things that surround us. His products include the 'Origami' table range (Elle Decoration Award for best table), the Anglepoise 'Fifty' light (shortlisted for the Design Museum's Brit Insurance Product of the Year) and the 'Around' clock for Lexon. He has been commissioned by commercial companies such as Red Bull, Veuve Clicquot and Audi. Dickens is also a founding partner of award winning creative agency, Together Creative.



COHDA

Cohda are a unique studio of Creatives, Product Designers, Engineers, Electronic Experts and Material Researchers. Based in the UK Cohda use the latest technology, materials, tools and software to deliver unique product solutions. With an impressive array of clients, including Apple, Foster + Partners and Louvre Abu Dhabi, to name but a few, they bring world-first products and technology to life. With their vast experience, Cohda stay one step ahead of competitors, inventing exciting products and new technology for world leading brands.



Flynn Talbot

Flynn Talbot operates a specialized lighting design studio based in London, UK. He designs innovative lighting fixtures for mass production and lighting installations for galleries and unique buildings. Each project begins with the consideration of the "light effect" and every product is constructed around it. By continually considering the quality of light and user connection, Talbot creates timeless products and a strong point of difference in his work. Talbot designs for various high quality lighting manufacturers and has exhibited his work throughout Europe, Australia and the U.S.A.



James Bartlett

James Bartlett studied at Manchester Metropolitan and joined Innermost's London studio in 2008, later taking the position of Design Manager. His design is characterised by an interest in material and process and he enjoys being in the workshop to participate in every stage of production. Portland is a great example of this: what began as a project to experiment with a cast concrete process developed into the unique product available in both concrete and plaster. Deliberately coarse and bubbly concrete holding a strong contrast against flawlessly smooth plaster surface.



Melissa Yip

Melissa Yip studied Product Design in Hong Kong Polytechnic University, before her internship in Innermost sparked her interest towards decorative lighting design. She joined Innermost after graduation and designed the Bud light in response to a brief set to the in-house team: to create something within the category of portable lighting but with a distinctly 'Innermost' twist. Taking inspiration from her design hero Naoto Fukasawa, she is passionate about exploring with form language and colours.



Steve Jones

After studying Industrial Design at Newcastle Polytechnic, Steve Jones started his career in design consultancy. His highly diverse design experience included ladies shoes, books, toys and even naval architecture. Later he worked extensively in the furniture industry, before moving into lighting and forming Innermost with Russell Cameron in 1999.

His varied interest in design is reflected in the diverse aesthetic of the Innermost collections. As well as his own designs, Jones has brought in names like Michael Young, Jarrod Lim, Corinna Warm, Stone Designs and Shin Azumi, helping to shape a range that has breadth as well as depth.



Jake Phipps

Jake Phipps graduated from John Makepeace's furniture design school, Parnham College, in 1999. In 2005, he set up his own design studio in London, concentrating on his own pieces.

His work is characterized by a narrative yet functional aesthetic full of character and with a playful design elegance that aims to strike a strong emotional chord with the people that use them.



Stone Designs

Designers Cutu Mazuelos and Eva Prego established Stone Design Concepts Inc. in 1995 to tell a story from their perspectives and without censorship. Having never worked for anyone else, lessons were learned and skills were mastered through personal hardship and sacrifice. Starting with interior designs, stands and displays, they worked with such names as Lexus, Telepizza, Havalanas, and Coca Cola. They also designed furniture for brands such as Muji Japan. Stone Designs is the constant search for new languages, a passion and reason for living.



YOY

YOY [joi] is a Tokyo based design studio composed by Naoki Ono, a spatial designer, and Yuki Yamamoto, a product designer. Naoki Ono was born in Nagoya, and graduated in architectural design at Kyoto Institute of Technology in 2008. Also born in Nagoya, Yuki Yamamoto graduated in industrial design at Kanazawa College of Art in 2008. Started in 2011, the design theme of YOY is to create a new story between space and objects. Steve Jones and Russell Cameron first spotted YOY in April 2013 at Salone Satellite in Milan.

**Innermost
&
the industry**



Manufacture

We are passionate about each design and every level of detail that goes into its manifestation. We have always placed production where the best skills can be found for the material or process. We travel across the globe sourcing the best quality materials and the most suitable producers for each product and every component. Whether we are prototyping in Hong Kong, using hand-blown glass by artisans in the Czech Republic, or doing bespoke engineering at our factory in the UK, we stay close to the manufacturing development at every level.



Bespoke design & OEM

After 19 years, we continue to produce many of our lights and lampshades in the UK, at our facility in Telford, with ownership over everything from production, assembly, testing, packaging, and warehousing. This in-house management of the entire process allows us to guarantee the highest standard of quality, as well as giving us full flexibility when it comes to bespoke product.

We often use our expertise to develop and manufacture products for other high-end design houses in an OEM capacity. From licensing and manufacturing existing designs, to providing a full design consultancy, we offer a unique and tailored service and are able to produce in high volume and absolute one-offs. Please contact us if you are interested in hearing more about our design and production services.







